



Determination of the combustion rate of titanium and zirconium metal powders

Basic principle

The metal powder to be tested is first loosened and then spread evenly into the specified metal channel. The material is ignited at one end and the time taken for the ignition spark to pass along a given combustion distance is measured.

Procedure

The titanium or zirconium metal powder is first loosened by passing it through a close mesh sieve. The powder is then poured loosely into the metal channel, lightly smoothed flat e. g. by a flexible paper card, playing card or the like and scraped to remove the excess. A small heap of the powder is placed in front of the start mark, and is lit with a small flame. A stop watch is used to measure the progress of combustion between the start and finish marks of the combustion distance. A slow-burning powder can be measured over a distance of 10 cm, and a fast-burning powder over a distance of 50 cm. The combustion rate is quoted in sec/50 cm, and is an important parameter for the manufacture of pyrotechnical materials.

Determination of the combustion rate of titanium and zirconium metal powders

Avoiding Discrepancies

1. The combustion rate depends on the amount of powder spread in the metal channel. To prevent subjective influences, it is advisable to check the amount spread by means of its weight, using the following procedure:

Place a predetermined quantity of metal powder (10 - 15 g) on the metal channel, spread it smooth and weigh off the excess powder after it has been scraped off. The weight of the excess deducted from the original weight yields the test amount. In this case the combustion rate can also be quoted in sec/g.

2. The MIL-specification Z 399-D also gives the description of a procedure for measurement of the combustion rates of zirconium and titanium metal powders. This MIL-procedure is different from our method and gives different results. Please make sure not to mistake both methods!

As a rule of thumb the combustion rate of powders measured by the MIL-procedure is approximately one third (1/3) of that measured by Chemetall method. Our long term experience with both methods showed that our method as described above seems to be more accurate and reproducible. All combustion rates given in this delivery program are measured by Chemetall method if not stated otherwise.

Apparatus

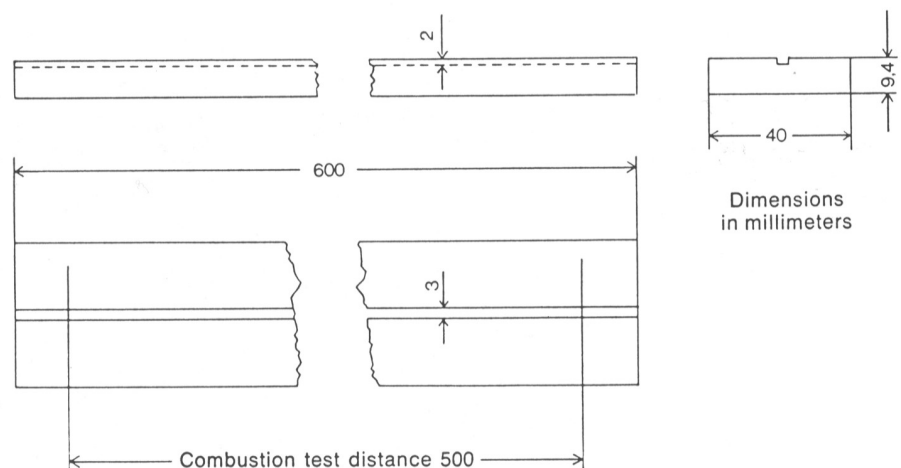

Edition: January 2001

Chemetall GmbH

Special Metals Division

Trakehner Straße 3
D-60487 Frankfurt am Main
P.O. Box 90 01 70
D-60441 Frankfurt a.M.
Phone +49 69 7165-3911
Fax +49 69 7165-2523
Mail specialmetals@chemetall.com

The above details have been compiled to the best of our knowledge on the basis of thorough tests and with regard to the current state of our long practical experience.

No liabilities or guaranties deriving form or in connection with this leaflet can be imputed to us. Reproduction in whole or in part, only for personal use.